



(19) **United States**

(12) **Patent Application Publication**  
**KHANDANI et al.**

(10) **Pub. No.: US 2011/0103795 A1**

(43) **Pub. Date: May 5, 2011**

(54) **SOFT DECODING OF DATA IN A COHERENT OPTICAL RECEIVER**

**Publication Classification**

(51) **Int. Cl.**  
**H04B 10/06** (2006.01)  
(52) **U.S. Cl.** ..... **398/65; 398/208**  
(57) **ABSTRACT**

(75) **Inventors:** **Amir Keyvan KHANDANI**,  
Kitchener (CA); **Han SUN**, Kanata  
(CA); **Kim B. ROBERTS**, Nepean  
(CA)

(73) **Assignee:** **NORTEL NETWORKS LIMITED**, St. Laurent (CA)

(21) **Appl. No.:** **12/608,022**

(22) **Filed:** **Oct. 29, 2009**

In a coherent optical receiver receiving a polarization multiplexed optical signal through an optical communications network, a method of compensating noise due to polarization dependent loss (PDL). A Least Mean Squares (LMS) compensation block processes sample streams of the received optical signal to generate symbol estimates of symbols modulated onto each transmitted polarization of the optical signal. A decorrelation block de-correlates noise in the respective symbol estimates of each transmitted polarization and generating a set of decorrelated coordinate signals. A maximum likelihood estimator soft decodes the de-correlated coordinate signals generated by the decorrelation block.

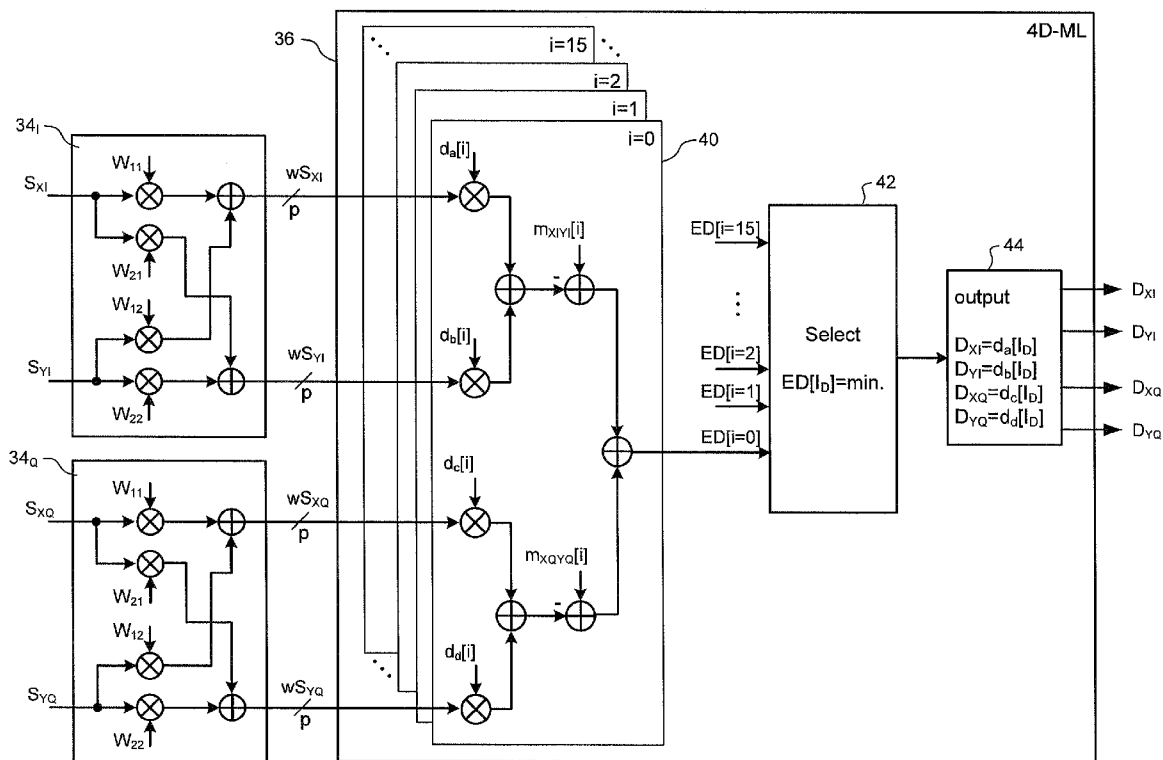

Figure 1  
(Prior Art)

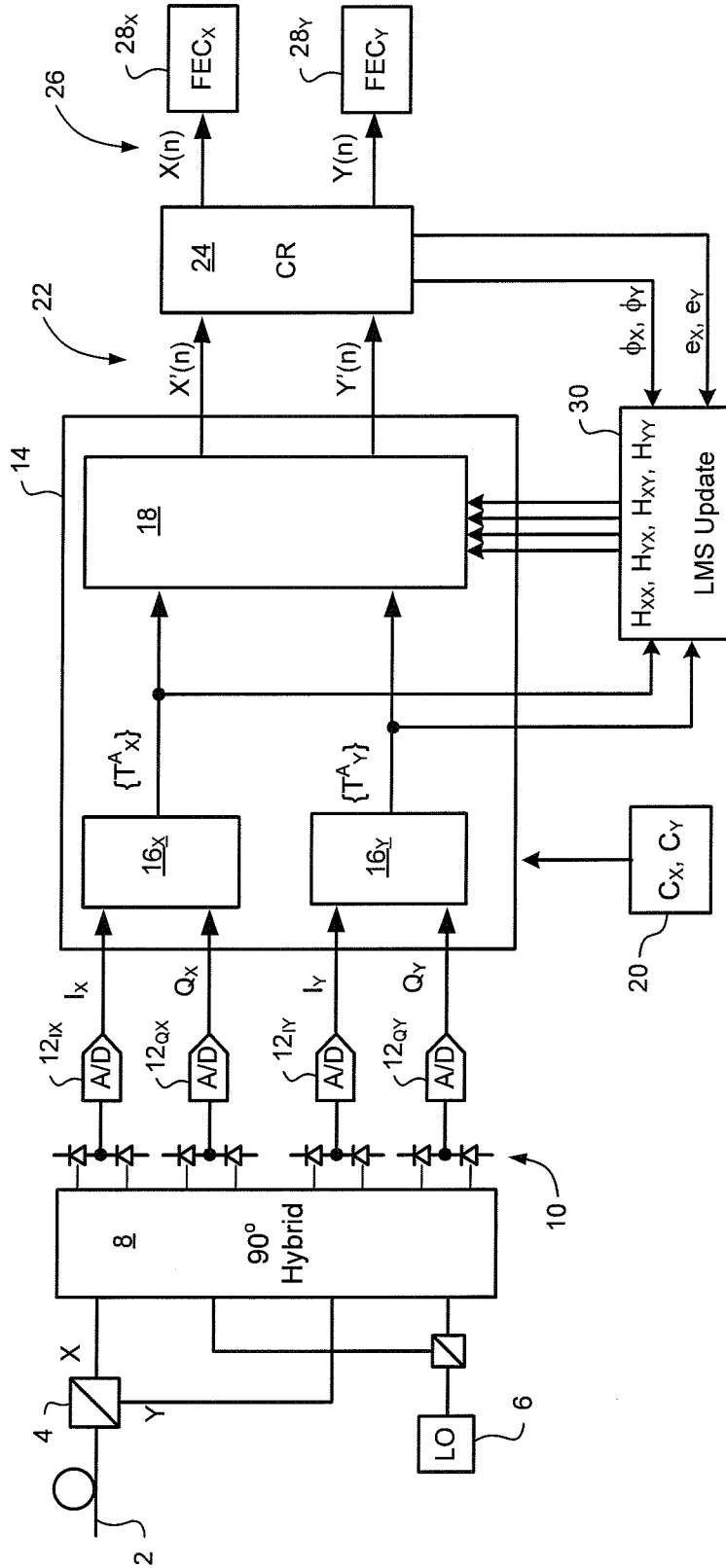
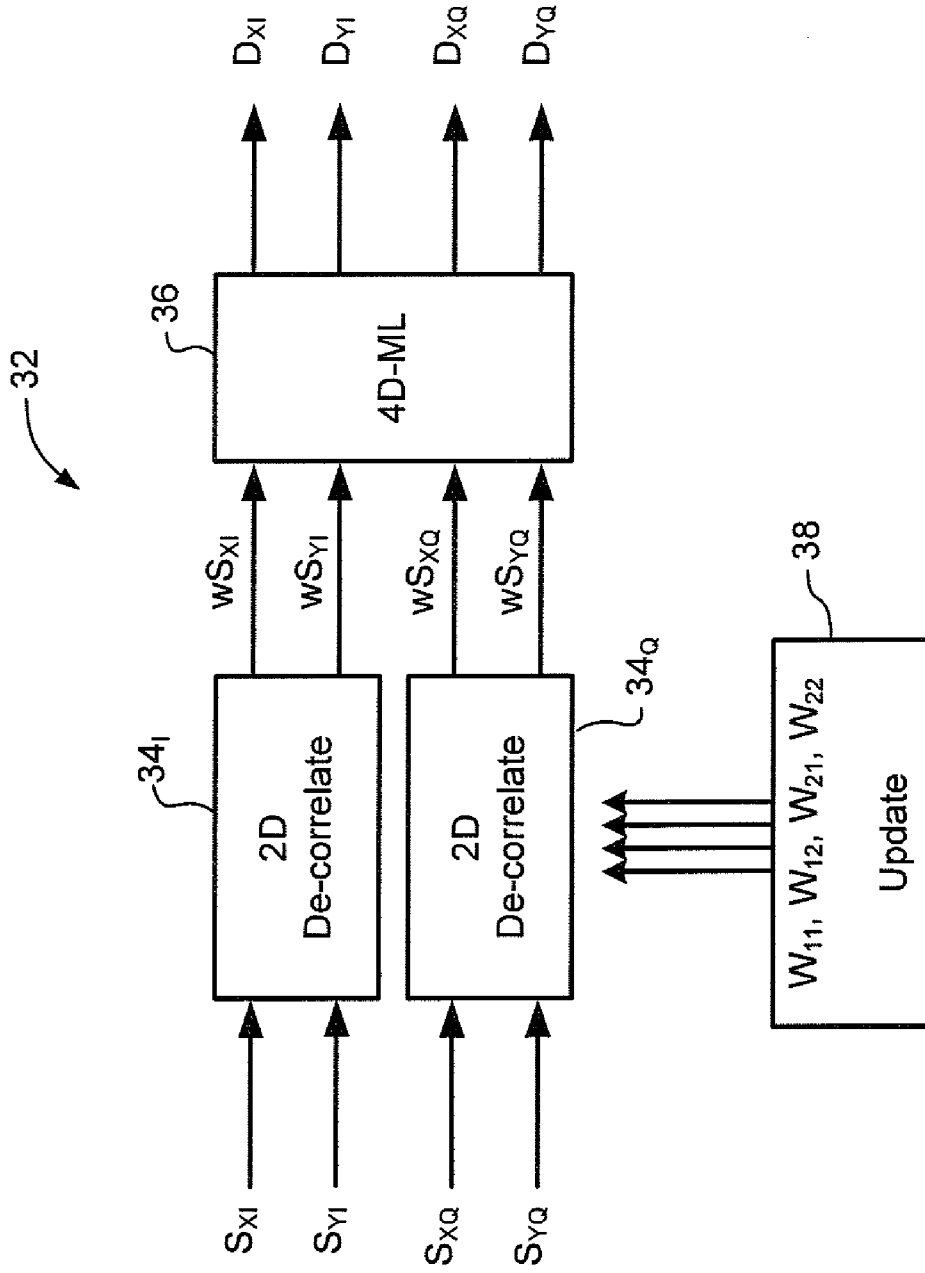

Figure 2



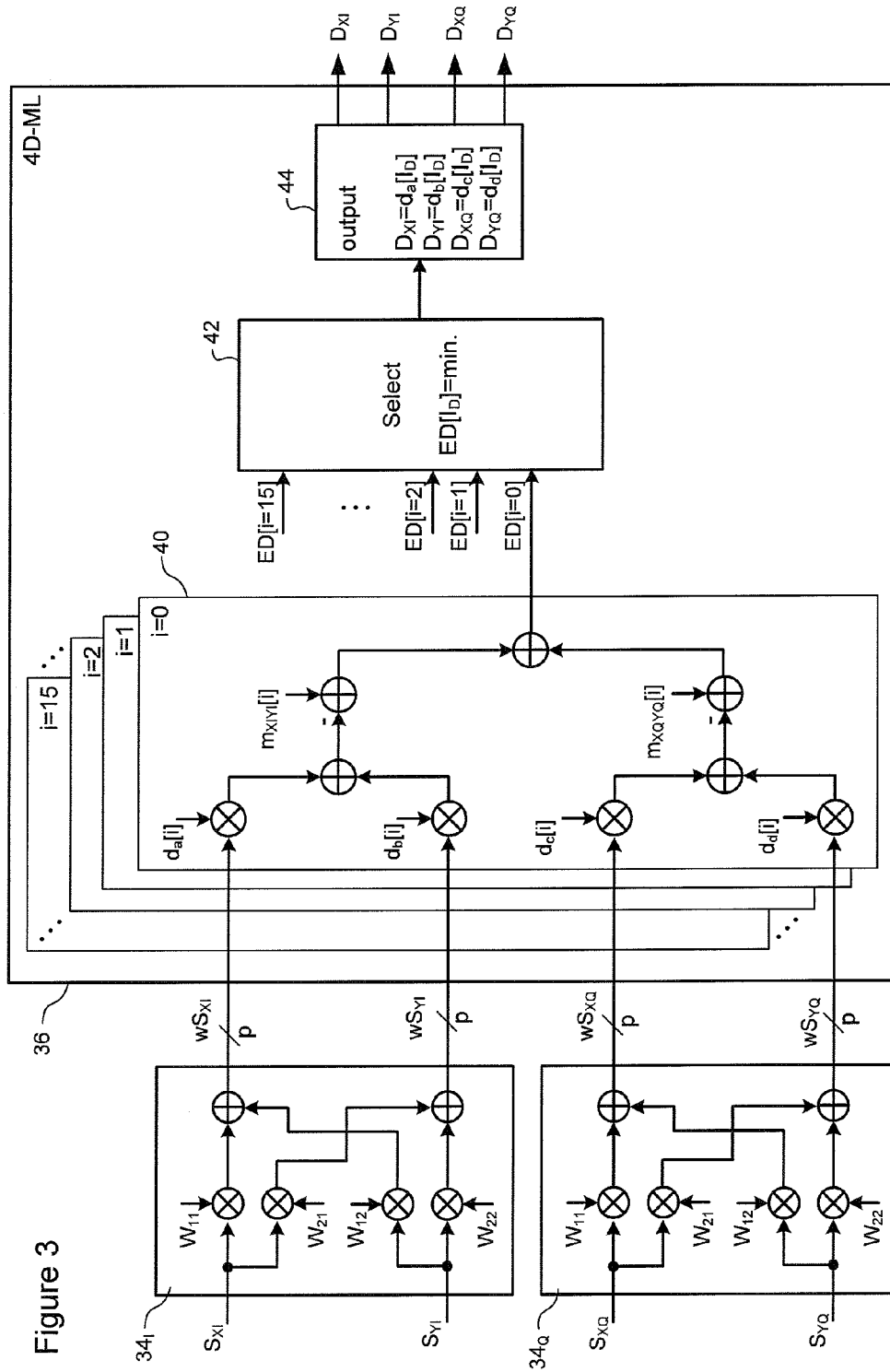

Figure 3

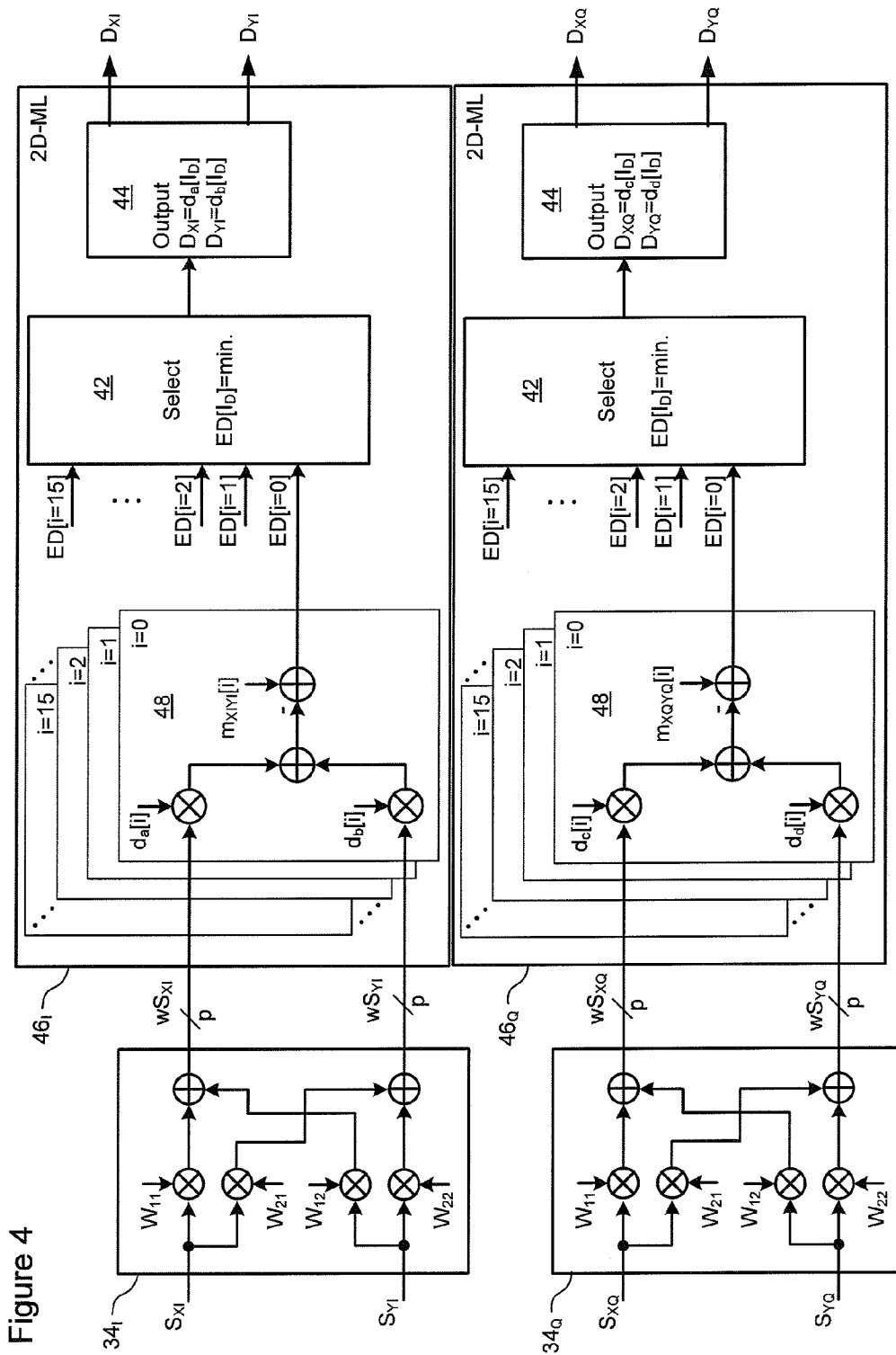

Figure 4

## SOFT DECODING OF DATA IN A COHERENT OPTICAL RECEIVER

### CROSS-REFERENCE TO RELATED APPLICATIONS

[0001] This is the first application filed in respect of the present invention.

### MICROFICHE APPENDIX

[0002] Not Applicable.

### TECHNICAL FIELD

[0003] The present invention relates to coherent optical receivers in optical communications systems, and more particularly to soft decoding of data in a coherent optical receiver.

### BACKGROUND OF THE INVENTION

[0004] FIG. 1 illustrates a coherent optical receiver known, for example, from Applicant's co-pending U.S. patent application Ser. No. 11/551,367 filed Oct. 20, 2006, U.S. patent application Ser. Nos. 11/315,342 and 11/315,345, both of which were filed Dec. 23, 2005, and U.S. patent application Ser. No. 11/950,585 filed Dec. 5, 2007. The entire contents of U.S. patent application Ser. Nos. 11/551,367, 11/315,342, 11/315,345 and 11/950,585 are incorporated herein by reference.

[0005] As may be seen in FIG. 1, an inbound optical signal is received through an optical link 2, split into orthogonal received polarizations (X and Y) by a Polarization Beam Splitter 4, and then mixed with a Local Oscillator (LO) signal 6 by a conventional 90° optical hybrid 8. The composite optical signals emerging from the optical hybrid 8 are supplied to respective photodetectors 10, which generate corresponding analog electrical signals. The photodetector signals are sampled by respective Analog-to-Digital (A/D) converters 12 to yield raw multi-bit digital signals  $I_X$ ,  $Q_X$  and  $I_Y$ ,  $Q_Y$  corresponding to In-phase (I) and Quadrature (Q) components of each of the received polarizations (X, Y).

[0006] From the A/D converter 12 block, the respective n-bit signals  $I_X$ ,  $Q_X$  and  $I_Y$ ,  $Q_Y$  of each received polarization are supplied to an agile signal equalizer 14 which operates to compensate chromatic dispersion and polarization rotation impairments. In general, the signal equalizer 14 comprises a respective dispersion compensation block 16 for each of the X- and Y-polarizations, and a polarization compensation block 18. The dispersion compensation blocks 16 have a width sufficient to enable compensation of moderate-to-severe dispersion (e.g. on the order of 10000 ps/nm) based on a set of dispersion compensation coefficients 20, and generate respective intermediate vectors  $\{T^d_X\}$  and  $\{T^d_Y\}$ . These intermediate vectors  $\{T^d_X\}$  and  $\{T^d_Y\}$  are then input to the polarization compensation block 18, which uses a set of polarization compensation vectors  $H_{XX}$ ,  $H_{XY}$ ,  $H_{YX}$  and  $H_{YY}$  to impose a phase rotation which compensates polarization impairments of the optical signal, and so de-convolve the transmitted symbols from the raw digital sample streams  $I_X$ ,  $Q_X$ , and  $I_Y$ ,  $Q_Y$  generated by the A/D converters 12. The compensated signals 22 output from the equalizer 14 represent multi-bit estimates  $X'(n)$  and  $Y'(n)$  of the symbols encoded on each transmitted polarization of the received optical signal. These symbol estimates  $X'(n)$ ,  $Y'(n)$ , are supplied to a carrier recovery block 24 for LO frequency control, symbol detec-

tion and data recovery, such as described in Applicant's co-pending U.S. patent application Ser. No. 11/366,392 filed Mar. 2, 2006.

[0007] The recovered data 26 output from the carrier recovery block 24 comprises respective decision values  $X(n)$ ,  $Y(n)$  of the symbols modulated onto each transmitted polarization of the received optical signal. Note that in the present description, "n" is an index of each transmitted symbol. These decision values  $X(n)$ ,  $Y(n)$  are passed to respective X- and Y-polarization decoding blocks 28 (such as, for example, a Forward Error Correction (FEC) block, Viterbi decoder, Low Density Parity Check (LDPC) decoder, Turbo decoder etc.) for error correction and data recovery.

[0008] In general, the decision values 26  $X(n)$ ,  $Y(n)$  output from the carrier recovery block 24 have the same format as the originally transmitted symbols modulated onto each transmitted polarization. If desired, the decision values  $X(n)$ ,  $Y(n)$  may be demultiplexed (or otherwise processed) to obtain a set of recovered signals corresponding to the original signals encoded in the transmitted symbols. For example, Applicant's U.S. Pat. No. 7,522,841, which issued Apr. 21, 2009, teaches an arrangement in which four parallel tributary signals are bit-wise multiplexed to yield a pair of 2-bit symbol streams. Each symbol stream is then modulated and transmitted on a respective polarization using a Quadrature Phase Shift Keying (QPSK) or Quadrature Amplitude Modulation (QAM) modulation scheme. In such a case, the decision values 26  $X(n)$ ,  $Y(n)$  output by the carrier recovery block 26 would be 2-bit estimates of the symbols modulated on the respective transmitted polarization. These two-bit estimates may be decomposed to yield four parallel bit-streams respectively corresponding with the original tributary signals.

[0009] [See Paras 24-27] A Least Mean Squares (LMS) update block 30 computes the polarization compensation vectors  $H_{XX}$ ,  $H_{XY}$ ,  $H_{YX}$  and  $H_{YY}$  based on the intermediate vectors  $\{T^d_X\}$  and  $\{T^d_Y\}$ , as well as symbol phase  $\phi_X$ ,  $\phi_Y$  and error  $e_X$ ,  $e_Y$  information received from the carrier recovery block 24. As described in Applicant's co-pending U.S. patent application Ser. No. 11/950,585, the polarization compensation vectors  $H_{XX}$ ,  $H_{XY}$ ,  $H_{YX}$  and  $H_{YY}$  are updated at a sufficiently high rate to enable tracking, and therefore compensation, of polarization rotation transients at speeds on the order of 50 kHz.

[0010] In the coherent optical receiver of FIG. 1, polarization compensation is performed in the Jones Matrix domain using polarization compensation vectors  $H_{XX}$ ,  $H_{XY}$ ,  $H_{YX}$  and  $H_{YY}$  computed using an LMS algorithm, but other methods may equally be used. Recursive least squares, and constant modulus are two other examples of algorithms that can be used for calculation of the polarization compensation parameters. The polarization compensation can be implemented, for example, in the frequency domain, the time domain, the Jones Matrix domain, or combinations of such operations.

[0011] The coherent optical receiver of FIG. 1 is capable of data recovery from a high-speed optical signal (e.g. symbol rates above 10 Gbaud) composed of two independently modulated orthogonal polarizations, even in the presence of moderate to severe ISI due to chromatic dispersion (CD) and polarization mode dispersion (PMD), and polarization transients on the order of 50 kHz.

[0012] As will be appreciated from the above description, the decision values 26  $X(n)$ ,  $Y(n)$  contain residual noise, which is intended to be compensated by the decoding block (s) 28. Under normal conditions, the polarization compensa-

tion block **18** effectively removes any correlation between the X- and Y-polarization decision values  $X(n)$ ,  $Y(n)$ . This implies that the residual noise in the X- and Y-polarization decision values  $X(n)$ ,  $Y(n)$  is also un-correlated.

**[0013]** As is known in the art, Polarization Dependent Loss (PDL) can produce a state in which the X- and Y- polarizations of the received optical signal are not orthogonal. Under some circumstances, this can lead to a condition in which a residual noise correlation exists between the X- and Y-polarization decision values  $X(n)$ ,  $Y(n)$ . If the decoding blocks **28** are designed assuming that the noise is un-correlated, the presence of residual noise correlation can result in a performance penalty of up to about 2 dB. On the other hand, designing the decoding blocks **28** to perform error correction in the presence of noise correlation dramatically increases the complexity (and thus cost) of the decoding blocks and/or requires increased signal overhead for error correction, both of which are undesirable.

#### SUMMARY OF THE INVENTION

**[0014]** An aspect of the present invention provides a coherent optical receiver for receiving an optical signal through an optical communications network. A polarization compensation block processes sample streams of the received optical signal to generate symbol estimates of symbols modulated onto the optical signal. A decorrelation block at least partially de-correlates noise in the respective symbol estimates of each transmitted polarization and for generating a set of decorrelated coordinate signals. Finally, an estimator decodes de-correlated coordinate signals generated by the decorrelation block.

**[0015]** An advantage of the present invention is that residual noise correlation between X- and Y- polarization symbol estimates can be reduced, and Signal-to-Noise Ratio improved.

#### BRIEF DESCRIPTION OF THE DRAWINGS

**[0016]** Further features and advantages of the present invention will become apparent from the following detailed description, taken in combination with the appended drawings, in which:

**[0017]** FIG. 1 is a block diagram schematically illustrating a coherent optical receiver known from Applicant's co-pending U.S. patent application Ser. No. 11/551,367;

**[0018]** FIG. 2 is a block diagram schematically illustrating a soft decoder in accordance with a representative embodiment of the present invention;

**[0019]** FIG. 3 is a block diagram schematically illustrating the soft decoder of FIG. 2 in greater detail; and

**[0020]** FIG. 4 is a block diagram schematically illustrating a soft decoder in accordance with a second representative embodiment of the present invention;

**[0021]** It will be noted that throughout the appended drawings, like features are identified by like reference numerals.

#### DETAILED DESCRIPTION OF THE PREFERRED EMBODIMENT

**[0022]** The present invention provides a method and system for compensating Polarization Dependent Loss (PDL) in a coherent optical receiver of the type described above with reference to FIG. 1. A representative embodiment of the present invention is described below with reference to FIGS. 2-4.

**[0023]** As noted above, Polarization Dependent Loss (PDL) can cause a condition in which residual noise correlation exists between the X- and Y-polarization decision values  $X(n)$ ,  $Y(n)$  generated by the carrier recovery block **24**. In very general terms, the present invention exploits this noise correlation to both de-correlate the noise and improve the signal to noise ratio (SNR) in the decision values  $X(n)$ ,  $Y(n)$ . During periods of rapidly changing PDL, the effect of this technique may be very low, but it will not further degrade the SNR. However, when PDL is slowly changing or constant, the present technique can yield as much as about 1.4 dB improvement in SNR.

**[0024]** For the purposes of the present disclosure, it is convenient to consider the transmitted optical signal as a multi-dimensional symbol space comprising four orthogonal coordinates plus time. The four orthogonal coordinates comprise the respective real (In-phase) and imaginary (Quadrature) components of each of the transmitted X and Y polarisations. For notation purposes, the four coordinates may be denoted as XI, XQ, YI, and YQ, respectively, and signals of each coordinate may be denoted using the coordinate indicator as a subscript.

**[0025]** Within any given time interval (baud), data can be independently modulated onto any one or more of the four coordinates. Thus, a transmitted symbol can be represented as a constellation of between one and four coordinates, all of which are modulated onto the optical signal within a single time interval. The number of coordinates in a symbol/constellation is determined by the number of polarizations used and the number of components of each polarization used by the modulation scheme. The number of possible constellations is determined by the number of coordinates used in the symbol/constellation and the number of discrete values that each coordinate can assume, given the chosen modulation scheme. For example, a Binary Phase Shift Keying (BPSK) modulation scheme uses only one (typically the real) component of a given polarization. In a dual polarization system, both polarizations are used, so that each symbol will comprise a constellation of two coordinates, each of which can assume nominal values of either  $-1$  or  $+1$  at the transmitter. This means that there are a total of four possible constellations. QPSK and QAM modulation schemes use both of the I and Q components of a given polarization. In a dual polarization system, both polarizations are used, so that each symbol will comprise a constellation of four coordinates, each of which can assume nominal values of either  $-1$  or  $+1$  at the transmitter. This means that there are a total of 16 possible constellations. 16-QAM modulation also uses both components on each polarization, but in this case each coordinate can assume nominal values of  $-3$ ,  $-1$ ,  $+1$  or  $+3$  at the transmitter. In a dual-polarization system, this means that each 16-QAM symbol will comprise a constellation of four coordinates, and there are a total of 256 possible constellations. Note that other modulation schemes may equally be used. Frequency domain, sub-carrier or other modulation methods can be used to modulate symbols/constellations onto the optical signal.

**[0026]** In the receiver described above with reference to FIG. 1, each decision value  $X(n)$ ,  $Y(n)$  represents an estimate of the constellation coordinates modulated onto the corresponding polarization during a given time interval, denoted by  $(n)$ . As such, these decision values can be readily decomposed into the appropriate coordinate signals, in accordance with the known modulation scheme implemented in the transmitter. Thus, for example, in the case of QPSK, QAM and

16-QAM modulation schemes, the decision values  $X(n), Y(n)$  can be decomposed into four coordinate signals (denoted herein as  $S_{X_I}(n), S_{X_Q}(n), S_{Y_I}(n),$  and  $S_{Y_Q}(n)$ ) each of which represents an estimate of the nominal value assumed by the corresponding coordinate at the transmitter during the  $n^{\text{th}}$  time interval.

**[0027]** For convenience of description, examples are used in which each transmitted symbol comprises a constellation of between one and four coordinates, all of which are modulated onto the optical signal within a single time interval, denoted by  $(n)$ . However, it will be appreciated that this is not essential. In principle, a  $4N$ -dimensional symbol can be transmitted by modulating a respective set of four coordinates onto the optical signal during each of  $N$  successive time intervals.

**[0028]** A signal processing block designed to process two dimensions together is referred to herein as a two-dimensional (2D) processing block. Similarly, a signal processing block designed to process all four dimensions together is referred to herein as a four-dimensional (4D) processing block.

**[0029]** As is known in the art, light propagating through an optical fibre link experiences a polarization rotation and PDL. The polarization rotation can be represented using a Jones Matrix of the form:

$$PDL = J(\theta, \phi) * G_{PDL} = \begin{bmatrix} \cos(\theta)e^{-j\phi} & -\sin(\theta) \\ \sin(\theta) & \cos(\theta)e^{+j\phi} \end{bmatrix} * \begin{bmatrix} \frac{1}{\alpha} & 0 \\ 0 & \frac{1}{\beta} \end{bmatrix}$$

**[0030]** Where  $\alpha$  and  $\beta$  are the respective gains of the PDL principle axes of the link;  $\theta$  is the angle between the transmit polarisation vector and the principal axes of the link PDL; and  $\phi$  determines the shape of the elliptical polarization of the principal axes of the link PDL. When  $\phi=0$ , the launched optical signal is linearly polarized; and when  $\phi=\pi/2$ , the launched optical signal is circularly polarized.

**[0031]** Noise introduced into the optical signal, at some point along the link, is subject to only the PDL in the downstream portion of the link, which can be represented in this same manner. For the case of noise PDL, the angles  $\theta$  and  $\phi$  are denoted herein as  $\theta_N$  and  $\phi_N$ , and the gain parameters  $\alpha_N$   $\beta_N$  to distinguish them from the total PDL traversed by the optical signal launched by the transmitter.

**[0032]** As will be appreciated, the total noise at the receiver can be considered to be made up of multiple noises, each of which has experienced a different amount of PDL in dependence on the portion of the link traversed by the noise before it reached the receiver. Because the polarization compensation block **18** compensates polarization effects of the entire link, the PDL experienced by the noise is effectively over-compensated. It is this over-compensation of the noise PDL that leads, under some circumstances, to the residual noise correlation in the decision values **26**  $X(n)$  and  $Y(n)$  output by the carrier recovery block **24**.

**[0033]** For the purpose of compensating the residual noise correlation it is useful to consider the optical link as a set of sub-links, each of which extends from a respective point of injection of noise to the receiver. Each sub-link can therefore be modeled using the matrix form provided above, and noise

injected at that point can be defined as having respective values of  $\theta_N$  and  $\phi_N$ . An approximation of the total noise PDL can be representing using the same matrix form as provided above, with average values of the noise angles, which are denoted herein as  $\theta_N^{Avg}$  and  $\phi_N^{Avg}$ .

**[0034]** The average noise angles  $\theta_N^{Avg}$  and  $\phi_N^{Avg}$  can be found from the noise power covariance, using equations of the form:

$$\theta_N^{Avg} = \frac{\text{sign}(P_{XY}^{Re})}{2} \tan^{-1} \left( \frac{2 \cdot |P_{XY}^{Re}| + |P_{XY}^{Im}|}{P_{YY} - P_{XX}} \right)$$

and

$$\phi_N^{Avg} = \tan^{-1} \left( \frac{P_{XY}^{Im}}{P_{XY}^{Re}} \right) + p \cdot \pi \begin{cases} p = 0 & \text{if } (\beta^2 - \alpha^2) \cdot \frac{1}{2} \cdot \sin(2\theta_N^{Avg}) \geq 0 \\ p = 1 & \text{if } (\beta^2 - \alpha^2) \cdot \frac{1}{2} \cdot \sin(2\theta_N^{Avg}) < 0 \end{cases}$$

**[0035]** Division by zero is avoided by setting  $\phi_N^{Avg}=\pi/2$  in that case. The terms  $P_{XY}^{Re}$  and  $P_{XY}^{Im}$  are defined below.

**[0036]** Referring to FIG. 2, a soft decoder **32** in accordance with a representative embodiment of the present invention comprises a pair of 2D decorrelators **34** cascaded with a 4D estimator. As may be seen in FIG. 2, each decorrelator **34** receives a respective pair of coordinate signals  $S_{X_I}(n), S_{Y_I}(n)$  and  $S_{X_Q}(n), S_{Y_Q}(n)$  from the carrier recovery block **24**, and applies a decorrelation matrix  $W$  to generate a corresponding pair of decorrelated coordinate signals  $wS_{X_I}(n), wS_{X_Q}(n), wS_{Y_I}(n),$  and  $wS_{Y_Q}(n)$ . The decorrelation matrix  $W$  is computed by a matrix update block **38**, as will be described in greater detail below. The 4D estimator **36** processes the decorrelated coordinate signals  $wS_{X_I}(n), wS_{X_Q}(n), wS_{Y_I}(n),$  and  $wS_{Y_Q}(n)$  together to generate corresponding soft decode signals  $D_{X_I}(n), D_{X_Q}(n), D_{Y_I}(n),$  and  $D_{Y_Q}(n)$ , which represent the most likely estimates of the respective tributary signals modulated onto each coordinate of the transmitted optical signal. The soft decode signals  $D_{X_I}(n), D_{X_Q}(n), D_{Y_I}(n),$  and  $D_{Y_Q}(n)$  can be supplied to one or more conventional data recovery blocks **28** (such as, for example, Forward Error Correction (FEC) decoders, Viterbi decoders, Low Density Parity Check (LDPC) decoders, Turbo decoders etc.) for error correction and data recovery using known techniques.

**[0037]** FIG. 3 illustrates an embodiment of the soft decoder **32** of FIG. 2 in greater detail. As may be seen in FIG. 3, each decorrelator **34** performs a real-valued  $2 \times 2$  matrix multiplication using the decorrelation matrix  $W$ , to generate multi-bit decorrelated coordinate signals  $wS_{X_Q}(n), wS_{X_I}(n), wS_{Y_I}(n),$  and  $wS_{Y_Q}(n)$ . In some embodiments, each of the decorrelated coordinate signals has a resolution of  $p=8$  bits, but more or fewer bits resolution may be used if desired. The estimator **36** processes the decorrelated coordinate signals to determine the most likely transmitted constellation, and outputs a set of soft decode signals  $D_{X_I}(n), D_{X_Q}(n), D_{Y_I}(n),$  and  $D_{Y_Q}(n)$  corresponding to the nominal values of the identified constellation.

**[0038]** As will be appreciated, both the number of possible constellations, and their nominal values, are known in advance from the number of polarizations used and the modulation format used to generate the optical signal at the transmitter. The embodiment of FIGS. 2 and 3 is particularly suitable for the case of QPSK modulation format on both transmitted polarizations. As noted above, this scenario yields a total of 16 unique constellations, which may be identified as  $D[i]=\{d_{X_I}[i], d_{X_Q}[i], d_{Y_Q}[i]\}, i=0 \dots 15$ .



**[0039]** In general, the 4D estimator **36** can be a maximum likelihood (ML) estimator, implementing any suitable maximum likelihood algorithm known in the art for identifying the most likely transmitted constellation given the decorrelated coordinate signals  $wS_{XQ}(n)$ ,  $wS_{XQ}(n)$ ,  $wS_{YI}(n)$ , and  $wS_{YQ}(n)$  generated by the decorrelators **34**. For example, a Euclidean Distance between the decorrelated coordinate signals  $wS_{XQ}(n)$ ,  $wS_{XQ}(n)$ ,  $wS_{YI}(n)$ , and  $wS_{YQ}(n)$  and each possible constellation can be computed, and the constellation associated with the smallest Euclidean Distance selected as the most likely transmitted constellation. However, in many cases an approximation to a complete Maximum Likelihood algorithm can be successfully implemented and achieve satisfactory results.

**[0040]** For example, in the embodiment of FIG. 3, the 4D estimator **36** implements a simplified approximation of the above-noted Euclidean Distance algorithm which reduces the cost of the associated circuitry while still yielding satisfactory results. operates by computing a Euclidean distance  $ED[i]$  between each constellation  $D[i]$  and the decorrelated coordinate signals  $wS_{XI}(n)$ ,  $wS_{XQ}(n)$ ,  $wS_{YI}(n)$ , and  $wS_{YQ}(n)$  computed by the 2D decorrelators. The constellation  $D[i=I_D]$  for which the Euclidean distance  $ED[I_D]$  is the smallest value (that is,  $ED[I_D]=\min$ ) is selected, and its respective terms  $\{d_{XI}[I_D], d_{XQ}[I_D], d_{YI}[I_D], d_{YQ}[I_D]\}$  output as the soft decode signals  $D_{XI}(n)$ ,  $D_{XQ}(n)$ ,  $D_{YI}(n)$ , and  $D_{YQ}(n)$ . In the embodiment of FIG. 4, the Euclidean distance calculation block comprises a set of 16 parallel multiplier blocks **40**, each of which computes a Euclidean distance  $ED[i]$ , between the decorrelated coordinate signals  $wS_{XI}(n)$ ,  $wS_{XQ}(n)$ ,  $wS_{YI}(n)$ , and  $wS_{YQ}(n)$  and a respective one of the 16 constellations  $D[i]$ ,  $i=0 \dots 15$ . A selector block **42** receives each of the computed Euclidean Distances, and identifies the constellation  $D[i=I_D]$  for which the Euclidean distance  $ED[I_D]$  is the smallest value. An output block **44** then outputs the terms of the identified constellation  $D[i=I_D]$  as the soft decode signals  $D_{XI}(n)$ ,  $D_{XQ}(n)$ ,  $D_{YI}(n)$ , and  $D_{YQ}(n)$ .

**[0041]** If desired, the estimator **36** may also compute a soft metric  $r(n)$ , which reflects a degree of confidence in the soft decode signals  $D_{XI}(n)$ ,  $D_{XQ}(n)$ ,  $D_{YI}(n)$ , and  $D_{YQ}(n)$ . This soft metric may be either calculated for the entire symbol/constellation, alternatively a respective soft metric may be computed for each soft decode signal. In some embodiments, the soft metric  $r(n)$  is a log likelihood ratio, known in the art. Alternatively, an approximation of the log likelihood ratio may be used.

**[0042]** For example, a respective soft metric  $r_{XI}(n)$  can be computed for the soft decode signal  $D_{XI}(n)$  as follows. As noted above, the soft decode signal  $D_{XI}(n)$  is chosen as the respective component  $d_{XI}[i]$  of the constellation  $D[i=I_D]$  for which  $ED[I_D]=\min$ . Within the set of constellations  $D[i]$ ,  $i=0 \dots 15$ , there is a sub-set of constellations  $D'[j]$ ,  $j=0 \dots 0.7$  in which the corresponding component value  $d_{XI}[j]$  differs from  $D_{XI}(n)$ . The respective Euclidean distances  $ED[j]$  of each of the constellations within this subset can then be analysed to identify the constellation  $D'[j=I_C]$  for which the Euclidean distance  $ED[I_C]$  is the smallest value within the subset. The soft metric  $r_{XI}(n)$  can then be computed as the difference between  $ED[I_D]$  and  $ED[I_C]$ . A directly similar approach can be used to compute respective soft metrics for each of the other soft decode signals  $D_{XQ}(n)$ ,  $D_{YI}(n)$ , and  $D_{YQ}(n)$ .

**[0043]** In the embodiment of FIGS. 3 and 4, the decorrelation matrix  $W$  is a  $2 \times 2$  real-valued matrix which is computed by the update block to decorrelate noise in the X- and Y-polarization

decision values **26**  $X(n)$ ,  $Y(n)$  generated by the carrier recovery block **24**. In some embodiments, the received optical signal is known to contain Synch bursts comprising a sequence of known bits (or symbols) at known intervals. In such cases, the decorrelation matrix  $W$  can be updated during a period of  $2^M$  Synch bursts, using the known bit (or symbol) sequence of each Synch burst. In some embodiments, the parameter value  $M$  may have a value of between 4 and 24. In some embodiments, the value of  $M$  is selected to obtain a desired update frequency. For example, for an optical signal having a given Synch burst frequency,  $M$  may be selected to obtain an update frequency of 300 KHz.

**[0044]** In some embodiments, the decorrelation matrix  $W$  is computed using noise power  $P_X$  and noise power covariance  $P_{XY}$  data for each of the four dimensions of the received optical signal. For example, the average noise power on the XI dimension can be calculated as:

$$P_{XI} = \left( \frac{2^{-M}}{K} \sum_{k=0}^K \sum_{m=0}^{2^M} e_{XI}^2 \right) - O_{XI}^2$$

**[0045]** where  $K$  is the number of bits (symbols) in each Synch burst;  $e_{XI}$  is the error between each XI coordinate signal  $S_{XI}(n)$  output from the carrier recovery block **24** and its corresponding known coordinate value of the Synch burst; and  $O_{XI}$  is a direct current (DC) offset in the XI coordinate signal  $S_{XI}(n)$  output from the carrier recovery block **24** during each Synch burst.

**[0046]** In some embodiments, the offset  $O_{XI}$  is calculated as:

$$O_{XI} = \frac{\sum_{k=0}^{K-1} \sum_{m=0}^{2^M-1} SYNCH_{XI}[k, m]}{K \cdot 2^M} + correction_{XI}$$

**[0047]** where  $SYNCH_{XI}$  is the XI dimension of the received synch burst.  $Correction_{XI}$  is a multibit (eg 7 bit) value of an expected offset of the SYNCH pattern in the XI dimension. Closely similar formulations can be used to compute the average noise power on each of the XQ, YI and YQ dimensions.

**[0048]** Using the above formulation for the noise power, the real covariances for the X and Y polarizations can be calculated as

$$P_{YIXI} = \left( \frac{2^{-M}}{K} \sum_{k=0}^K \sum_{m=0}^{2^M} e_{YI} * e_{XI} \right) - O_{YI} * O_{XI}$$

$$P_{YQXQ} = \left( \frac{2^{-M}}{K} \sum_{k=0}^K \sum_{m=0}^{2^M} e_{YQ} * e_{XQ} \right) - O_{YQ} * O_{XQ}$$

and  $P_{XY}^{Re} = P_{XUYI} + P_{XQYQ}$

**[0049]** and the imaginary covariances for the X and Y polarizations can be calculated as

$$P_{XQYI} = \left( \frac{2^{-M}}{K} \sum_{k=0}^K \sum_{m=0}^{2^M} e_{XQ} * e_{YI} \right) - O_{XQ} * O_{YI}$$

$$P_{XIYQ} = \left( \frac{2^{-M}}{K} \sum_{k=0}^K \sum_{m=0}^{2^M} e_{XI} * e_{YQ} \right) - O_{XI} * O_{YQ}$$

and  $P_{XY}^{Im} = P_{XQYI} - P_{XIYQ}$

**[0050]** A real-value covariance matrix P' can then be defined as:

$$P' = \begin{bmatrix} P_{XX} & P_{XY}^{Re} \\ P_{XY}^{Re} & P_{YY} \end{bmatrix},$$

**[0051]** where  $P_{XX} = P_{XX} + P_{XQ}$ , and  $P_{YY} = P_{YY} + P_{YQ}$ . The real-valued decorrelation matrix W can then be formulated as

$$W = \begin{bmatrix} P_{YY} + \sqrt{\det(P')} & -P_{XY}^{Re} \\ -P_{XY}^{Re} & P_{XX} + \sqrt{\det(P')} \end{bmatrix}$$

**[0052]** Where  $\det(P')$  is the determinant of P'. In some embodiments, the covariance matrix P' can be scaled such that  $\det(P')=1$ , in which case the real-valued decorrelation matrix W can then be formulated as

$$W = \begin{bmatrix} P_{YY} + 1 & -P_{XY} \\ -P_{XY} & P_{XX} + 1 \end{bmatrix}$$

**[0053]** In the embodiment of FIGS. 2 and 3, a pair of parallel 2D decorrelators 34 are used, each of which applies a 2x2 real-valued decorrelation matrix W to decorrelate corresponding In-phase and Quadrature coordinate signals S from each polarization. In principal, a single 4D decorrelator implementing a 4x4 complex decorrelation matrix W could receive all four coordinate signals S and compute the corresponding multi-bit decorrelated signals wS, possibly with increased accuracy. However, it has been found that satisfactory decorrelation performance can be achieved, at lower cost, by applying a real-valued 2x2 decorrelation matrix W to each of the In-phase and Quadrature coordinate signals separately, as shown in FIGS. 2 and 3. With this arrangement, optimum decorrelation performance is obtained when the average noise angles  $\theta_N^{Avg} = \pi/4$  and  $\phi_N^{Avg} = 0$ , and degrades with variance from that point. For values of  $\phi_N^{Avg}$  far away from zero, the performance will degrade moderately compared to an embodiment using a full complex decorrelation matrix W. For values of  $\theta_N^{Avg}$  near to zero (or equivalently 90 degrees), the decorrelation matrix becomes ineffective. However, the embodiment of FIGS. 2 and 3 will not make the PDL worse than doing nothing with non-ideal polarization orientations, it just will not optimally mitigate the complex noise correlations.

**[0054]** Based on the foregoing, it will be seen that performance can be optimized by controlling the polarization angles of the transmitted optical signal in such a manner as to minimize the absolute value of  $\theta_N^{Avg}$ , and keep  $\theta_N^{Avg}$  near to 45 degrees. As noted above, the average noise angles  $\phi_N^{Avg}$  and  $\theta_N^{Avg}$  can be computed from the noise power covariances. This information can be sent to a transmitter and used to control the polarization state of the transmitted optical signal. Feed-back control techniques for controlling the polarization state of a transmitted optical signal, based on a feedback signal sent to the transmitter from a receiver, are known, for example, from U.S. Pat. No. 7,382,985, which issued Jun. 3, 2008. Typically, these techniques are designed to control the launch polarization state in such a way as to minimize polarization dependent effects (including PDL) experienced by the signal, for example by maintaining the launch polarization angle  $\theta$  at 45° with respect to the principle axes of the PDL in optical fibre link. In the present case, this operation is modified, such that the launch polarization angle  $\theta$  is controlled to yield  $\theta_N^{Avg} = 45^\circ$ , and  $\phi_N^{Avg}$  is minimized. Controlling the launch polarization state in this manner means that the optical signal received at the receiver will contain significant uncompensated PDL. However, the polarization compensation block 18 of the receiver (FIG. 1) can compensate this PDL, so its presence in the received optical signal does not seriously impair performance.

**[0055]** As noted above, the embodiment of FIGS. 2 and 3 is particularly suited for the case of QPSK modulation format on both transmitted polarizations. In principle this same architecture could also be used to process signals in which a 16-QAM modulation format on both transmitted polarizations. However, in this case a 4D ML estimator 36 would require 256 parallel multiplier blocks 40 in order to compute the Euclidian distance between each constellation  $D[i]$ ,  $i=0 \dots 255$ , and the decorrelated coordinate signals  $wS_{X_I}(n)$ ,  $wS_{X_Q}(n)$ ,  $wS_{Y_I}(n)$ ,  $wS_{Y_Q}(n)$ . A less expensive solution, which also has been found to yield satisfactory performance, is illustrated in FIG. 4.

**[0056]** As may be seen in FIG. 4, the 4D ML estimator 36 of FIGS. 2 and 3 is replaced by a pair of parallel 2D ML estimators 46 for processing respective pairs of the decorrelated coordinate signals  $wS_{X_I}(n)$ ,  $wS_{Y_I}(n)$ , and  $wS_{X_Q}(n)$ ,  $wS_{Y_Q}(n)$ . With this arrangement, the In-phase (real) and Quadrature (imaginary) coordinates are treated separately, and the number of possible constellations for each coordinate pair is 16. Accordingly, each 2D ML estimator 46 comprises a set of 16 parallel multiplier blocks 48, each of which computes the Euclidian distance  $ED[i]$ , between a respective one of the 16 constellations  $D[i]$ ,  $i=0 \dots 15$  and one pair of the decorrelated coordinate signals. A selector block 42 receives each of the computed Euclidean Distances and identifies the constellation  $D[i=D]$  for which the Euclidean distance  $ED[I_D]$  is the smallest value, and the output block 44 then outputs the applicable terms of the identified constellation as the soft decode signals  $D_{X_I}$ ,  $D_{X_Q}$ ,  $D_{Y_I}$ , and  $D_{Y_Q}$ .

**[0057]** The embodiment(s) of the invention described above is(are) intended to be exemplary only. The scope of the invention is therefore intended to be limited solely by the scope of the appended claims.

We claim:

1. In a coherent optical receiver receiving a polarization multiplexed optical signal through an optical communications network, a method of compensating noise due to polarization dependent loss (PDL), the method comprising, in the receiver:

- a Least Mean Squares (LMS) compensation block processing sample streams of the received optical signal to generate symbol estimates of symbols modulated onto each transmitted polarization of the optical signal;
- a decorrelation block de-correlating noise in the respective symbol estimates of each transmitted polarization and generating a set of decorrelated coordinate signals; and
- a maximum likelihood estimator soft decoding the decorrelated coordinate signals generated by the decorrelation block.

2. A coherent optical receiver for receiving an optical signal through an optical communications network, the receiver comprising:

- a polarization compensation block for processing sample streams of the received optical signal to generate symbol estimates of symbols modulated onto the optical signal;
- a decorrelation block for at least partially de-correlating noise in the respective symbol estimates of each transmitted polarization and for generating a set of decorrelated coordinate signals; and
- an estimator for decoding de-correlated coordinate signals generated by the decorrelation block.

3. The coherent optical receiver of claim 2, wherein the optical signal contains information on more than one polarization.

4. The coherent optical receiver of claim 3, wherein the optical signal comprises a polarization multiplexed optical signal.

5. The coherent optical receiver of claim 2, wherein the polarization compensation block implements any one of:

- a Recursive Least Squares (RLS) operation;
- a Constant Modulus (CM) operation;
- a Least Mean Squares (LMS) operation; and
- a Jones matrix operation.

6. The coherent optical receiver of claim 2, wherein the estimator comprises a Maximum Likelihood estimator or an approximation thereof.

7. The coherent optical receiver of claim 2, wherein the estimator further computes a soft metric.

8. The coherent optical receiver of claim 7, wherein a respective soft metric is computed for each transmitted symbol;

9. The coherent optical receiver of claim 7, wherein a respective soft metric is computed for each transmitted bit.

10. The coherent optical receiver of claim 9, wherein the soft metric is an approximation to the log of a likelihood ratio.

11. The coherent optical receiver as claimed in claim 2, wherein the symbols modulated onto each transmitted polarization of the optical signal are QPSK symbols, and wherein the decorrelation block comprises a pair of parallel 2-dimensional decorrelators, each 2-dimensional decorrelator applying a real-valued decorrelation matrix to a respective pair of coordinate signals derived from the symbol estimates to generate a corresponding pair of decorrelated coordinate signals.

12. The coherent optical receiver as claimed in claim 11, wherein a first one of the decorrelators applies the real-valued decorrelation matrix to respective In-Phase coordinate signals of each symbol estimate, and wherein a second one of

the decorrelators applies the real-valued decorrelation matrix to respective Quadrature coordinate signals of each symbol estimate.

13. The coherent optical receiver as claimed in claim 11, wherein the symbols modulated onto each transmitted polarization of the optical signal are QPSK symbols, and wherein the maximum likelihood estimator comprises a 4-dimensional maximum likelihood estimator for identifying one of a set of predetermined constellations that most closely matches the decorrelated coordinate signals generated by the pair of parallel 2-dimensional decorrelators.

14. The coherent optical receiver as claimed in claim 13, wherein the 4-dimensional maximum likelihood estimator comprises:

- a distance calculation block for computing a respective Euclidean distance between the decorrelated coordinate signals and each one of the predetermined constellations; and
- a selector for selecting the constellation for which the respective Euclidean distance is a minimum, and for outputting each term of the selected constellation as a respective soft-decoded coordinate signal.

15. The coherent optical receiver as claimed in claim 11, wherein the symbols modulated onto each transmitted polarization of the optical signal are 16-QAM symbols, and wherein the maximum likelihood estimator comprises a respective 2-dimensional maximum likelihood estimator associated with each 2-dimensional decorrelator, each 2-dimensional maximum likelihood estimator identifying one of a set of predetermined constellations that most closely matches the respective decorrelated coordinate signals generated by its associated 2-dimensional decorrelator.

16. The coherent optical receiver as claimed in claim 15, wherein each 2-dimensional maximum likelihood estimator comprises:

- a distance calculation block for computing a respective Euclidean distance between the respective decorrelated coordinate signals and each one of the predetermined constellations; and
- a selector for selecting the constellation for which the respective Euclidean distance is a minimum, and for outputting each term of the selected constellation as a respective soft-decoded coordinate signal.

17. In an optical communications network comprising a transmitter and a coherent optical receiver, the transmitter transmitting a polarization multiplexed optical signal having respective symbols modulated onto each polarization and having a predetermined polarization angle, the coherent optical receiver recovering respective symbol estimates of the symbols modulated onto each polarization by the transmitter, a method of compensating polarization dependent loss (PDL), the method comprising:

- a carrier recovery block of the receiver computing a respective symbol phase  $\phi$  of each symbol estimate;
- the transmitter adjusting the polarization angle of the transmitted optical signal to minimize the computed symbol phase  $\phi$ ; and
- a decorrelation block of the receiver de-correlating noise in the respective symbol estimates of each transmitted polarization.

18. The method of claim 15, further comprising computing a time average phase, wherein the polarization angle of the transmitted optical signal is adjusted to minimize the computed time average phase.

**19.** A system for compensating polarization dependent loss (PDL) in an optical communications network, the system comprising:

the transmitter for transmitting a polarization multiplexed optical signal having a predetermined polarization angle and respective symbols modulated onto each transmitted polarization;

a coherent optical receiver for recovering symbol estimates of the symbols modulated onto each transmitted polarization of the optical signal, the receiver comprising:

a carrier recovery block for computing a respective symbol phase  $\phi$  of each symbol estimate; and

a decorrelation block for de-correlating noise in the respective symbol estimates of each transmitted polarization

wherein the transmitter is controlled to adjust the polarization angle of the transmitted optical signal to minimize the computed symbol phase.

**20.** The system of claim **19**, wherein the polarization angle of the transmitted optical signal is adjusted to minimize a time average of the computed symbol phase.

\* \* \* \* \*